

Step 3 - Now tighten all Leg and Leg Brace Bolts.

Step 4 - At this point two adults should carefully lift the game upright and position it where the game will be played.

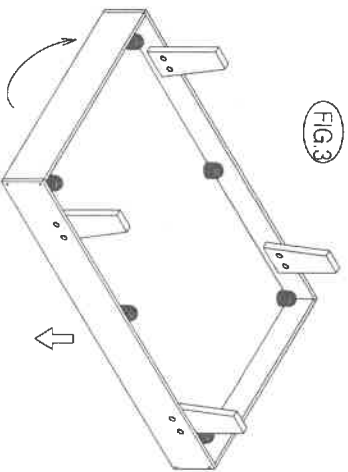

**CAUTION:** Two strong adults are recommended to flip the table as shown.  
1. Grab the table on the ground.  
2. Turn the table over.  
3. Place it on all four feet at the same time on the ground.

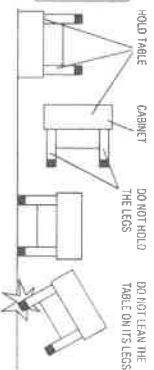

Step 5-Place a carpenter's level in various positions on the playing surface to determine where leveling adjustments may be needed and adjust the leg levelers as needed to ensure that the table is level.

**YOU ARE NOW READY TO PLAY**

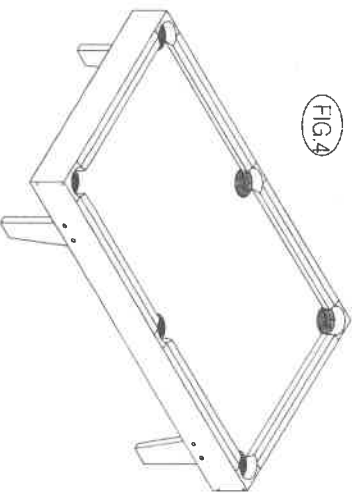

# Owners Manual

# Table Billiard

Model #SUB-3620-2

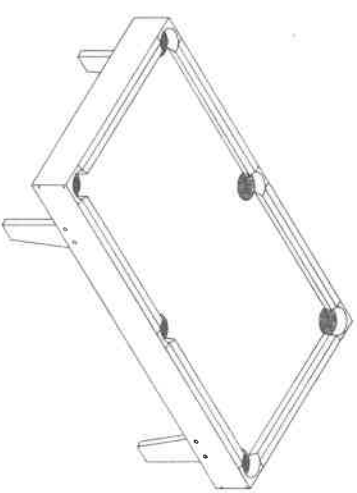

Assembly Instructions

Parts List

**MODEL#SUB-3620-2**

**WARNING:** Choking Hazard-- Toy contains small balls and/or small parts. Not for children under 3 years.

**IMPORTANT!**

**Please Keep Your Instructions.** Before attempting assembly, please read through this instruction book to familiarize yourself with all the parts and assembly steps. We recommend that two adults assemble this game. Please refer to the Parts List below and be sure that all parts have been included.

**PARTS LIST**

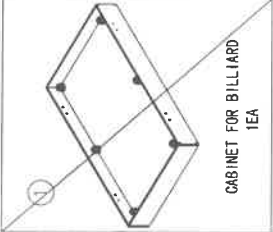
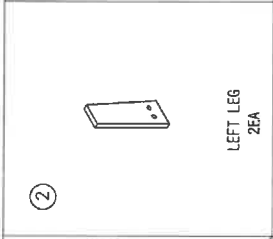
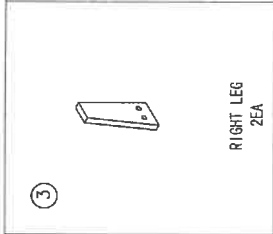
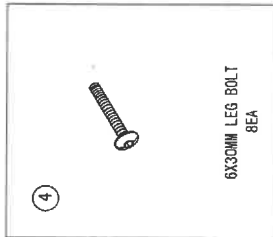
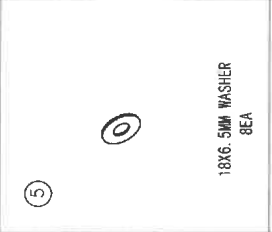
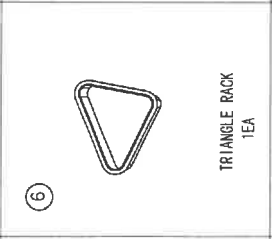
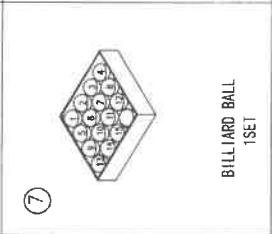
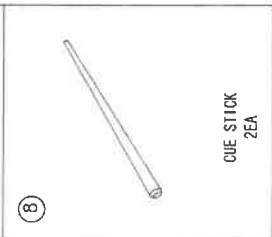
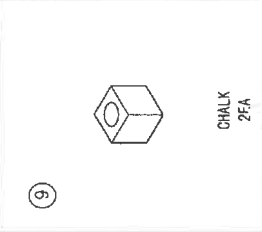
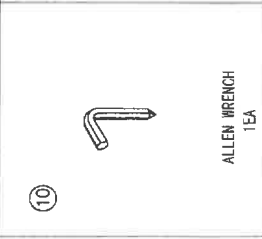
 <p>1 CABINET FOR BILLIARD 1EA</p>	 <p>2 LEFT LEG 2EA</p>	 <p>3 RIGHT LEG 2EA</p>	 <p>4 6X30MM LEG BOLT 8EA</p>
 <p>5 18X6.5MM WASHER 8EA</p>	 <p>6 TRIANGLE RACK 1EA</p>	 <p>7 BILLIARD BALL 1SET</p>	 <p>8 CUE STICK 2EA</p>
 <p>9 CHALK 2EA</p>	 <p>10 ALLEN WRENCH 1EA</p>		

**ASSEMBLY INSTRUCTIONS:**

We recommend that two adults work together to assemble this game.

**Step 1 -** Open the carton of your new billiard game near where your game will be played. Select a clear level floor. The table will be assembled upside down and then turned over onto its legs. This is a very heavy table game and turning it over will require at least two strong adults. Use the bottom carton to assemble the game and protect the game. Carefully cut or tear the carton corners so that bottom carton becomes a flat working surface area.

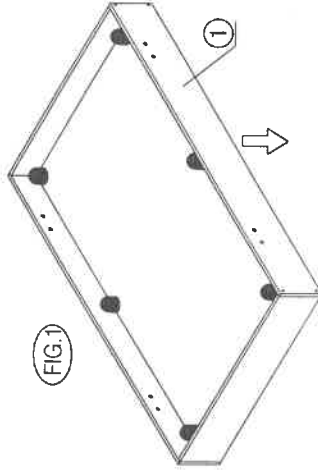

**Step 2 -** Attach the Left (#2) and Right (#3) Legs to the support frame using two of Leg Bolts (#4) and two of Washers (#5) per Leg. See FIG. 2.

